

BARRIERS

STEEL
TUBULAR STRUCTURES



Application areas

- ◆ HYPERMARKETS
- ◆ GARDEN CENTER
- ◆ DIY
- ◆ SUPERMARKETS
- ◆ DISCOUNT

DESCRIPTION

Designed to delimit the areas of the sales surfaces, they allow designers to create devices intended to direct customers along defined paths.

They are an extra weapon to protect the perimeters of the sales areas from possible thefts without compromising the aesthetics of the store. Modular and easy to install, they are made using uprights in chromed or painted steel of diam. equal to 48 mm and chromed tubular diam. 40 mm. Rectangular steel base hidden by cover (base cover) in chromed or painted steel. The connecting sleeves are made of chromed or paintable zamak.

COLORS & CUSTOMIZATIONS



CHROMED STEEL



ANTHRACITE



CUSTOM

ANY RAL COLOUR

FEATURES

Uprights	Diameter 48 mm
Weight	15 kg
Standard	In according to CE Certification

MATERIALS

Uprights and finishes (std)	chromed or painted steel
Cap and Base cover	chromed or painted steel
Connection clip	chromed polycarbonate or chromed and paintable zamak

SIZES - LATERAL VIEW

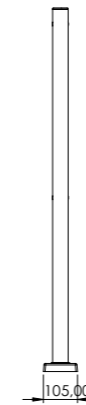

SIZES - FRONT VIEW

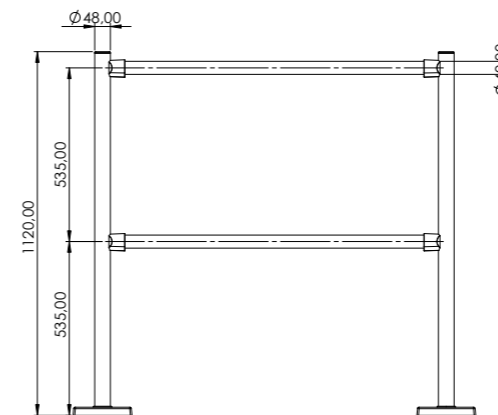

SIZES - TOP VIEW

